

Company: \_\_\_\_\_  
 Address: \_\_\_\_\_  
 Street: \_\_\_\_\_  
 Zip/City/Country: \_\_\_\_\_  
 Contact person: \_\_\_\_\_ Department: \_\_\_\_\_  
 Telephone: \_\_\_\_\_ Fax: \_\_\_\_\_  
 E-Mail: \_\_\_\_\_

The **Tray Stapling Machine SHA** is being manufactured in different versions. In order to submit you a suitable offer please answer the following questions as detailed as possible.

**Tray Stapling Machine SHA**, fully automatic forming and stapling of large cardboard blanks into trays.

**Please send tray samples to determine the correct staple size.**

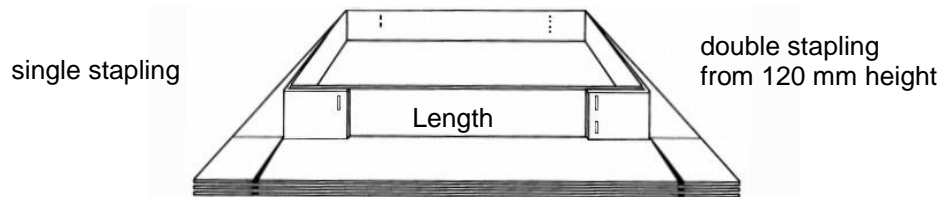

**A) Dimensions of blanks**  
 Length x Width x Height (mm)

1. \_\_\_\_\_
2. \_\_\_\_\_
3. \_\_\_\_\_
4. \_\_\_\_\_
5. \_\_\_\_\_

for additional sizes please add separate description alternatively:

Length: from \_\_\_\_\_ mm to \_\_\_\_\_ mm  
 Width: from \_\_\_\_\_ mm to \_\_\_\_\_ mm  
 Height: from \_\_\_\_\_ mm to \_\_\_\_\_ mm

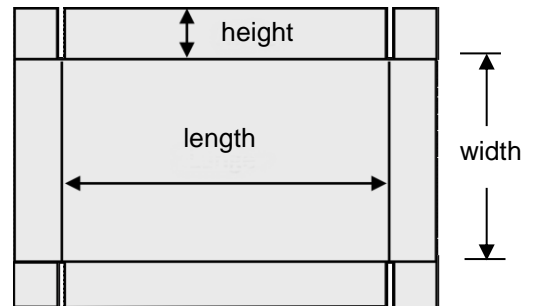
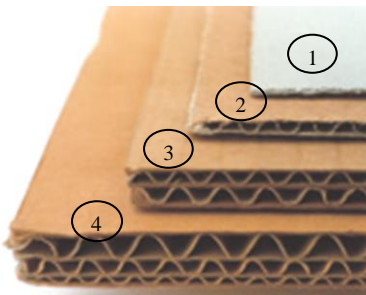

Illustration shows standard cut.  
 For different shapes please send sketch.

**B) Carton quality**

- 1) Solid cardboard
- 2) Single corrugated cardboard
- 3) Double corrugated cardboard
- 4) Triple corrugated cardboard

For testing please send samples.



**C) Carton output**

\_\_\_\_\_ pcs. per hour.

- we work single shift.
- we work double shift.

**D) Range of adjustability**

\_\_\_ pcs. of carton trays of the same size come in series before the next tray size is required.

**E) Forming carton blanks into trays**

- a) Flaps are folded outside on length side (standard version).
- b) Flaps are folded inside on length side.
- c) We have special trays (e.g. blunt corners) and are sending attached detailed sketch.

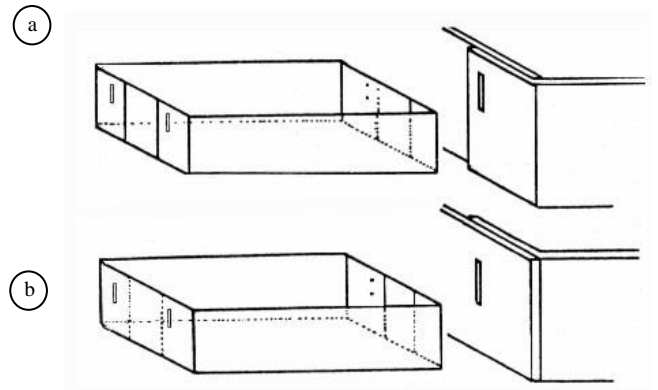

**F) Coiled staples**

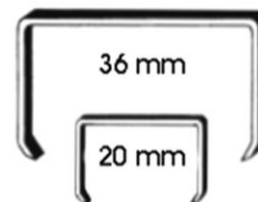
- With 36 mm crown size (standard version).
- With 20 mm crown size (for smaller trays only).

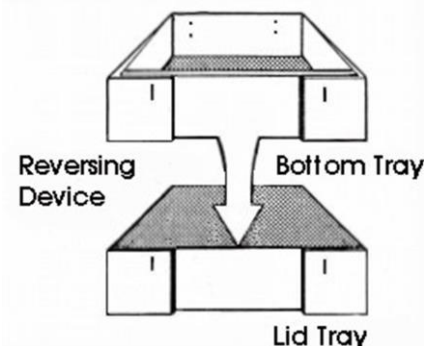

**MG® Coiled staples**
**G) Reversing device**

Carton Trays are provided for transportation or ejected at output station.

- Output station will eject resp. hold ready for ejection a bottom tray – open at top (standard version).
- With reversing station, a bottom tray can be turned to a lid tray – open bottom.

**H) Application**

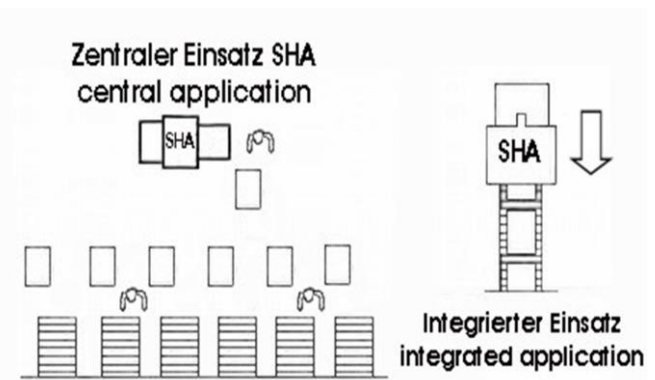
- a) Central application:  
SHA machine will operate in a central position in order to supply several packaging lines.
- b) Integrated application:  
SHA machine will be integrated in the packing line to supply one or two particular lines with the same tray size.



In case of integrated application (Hb) please answer the following questions:

**I) Machine height for handing over the carton trays**

- a) In the standard version carton tray will be handed over in a height of 1,100 mm.
- b) In case of larger quantities of the same tray size the machine can be delivered in an elevated version. Height of handing over 2,500 mm which means 1,600 mm carton blanks plus wooden pallet (when using automatic entering device "L").
- c) see b) but height of handing over 1,750 mm, which corresponds to 865 mm carton blanks plus wooden pallet (when using automatic entering device "L").
- d) Any other handing over height:  
 Required handing over height: \_\_\_\_\_ mm.

When using a reversing device the handing over height for top tray will be increased by one tray height.

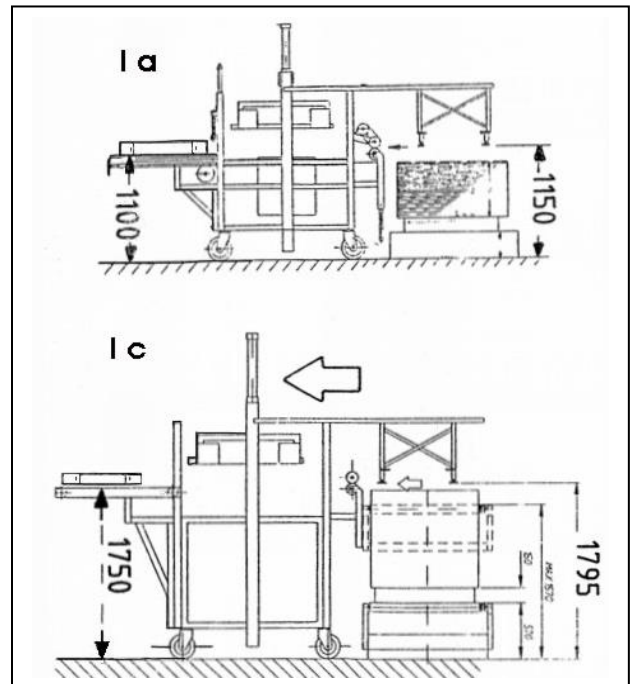

**J) Handing over the carton trays**

- a) The lifting of the trays is NOT part of the MEZGER machine SHA. The tray is provided for transportation. It is not centered.
- b) dto, but tray has to be centered.
- c) Trays (bottom or lid) will be pushed over onto an existing conveyor belt. This conveyor belt is about 50mm below the ejection section of the machine SHA.

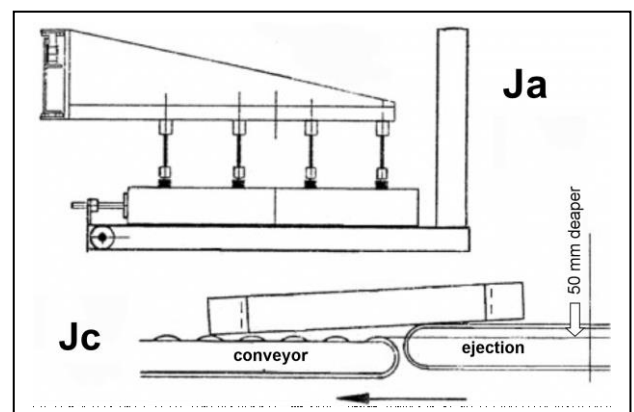

**K) Direction of handing over the carton trays**

- a) The tray will be handed over straight (s. sketch)
- b) The tray will be pushed on a 90° tray section and from there pushed to the right on a conveyor.
- c) See b), but pushed to the left on a conveyor.

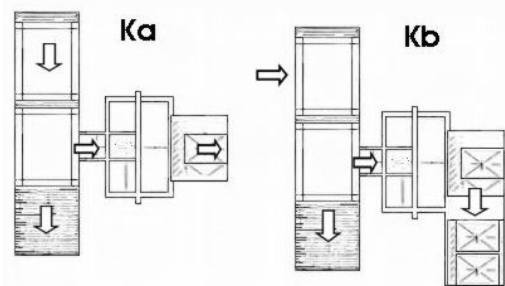

**L) Automatic pallet loading station for blank-pallet**

For machines in elevated version we recommend an additional pallet loading device. The blank pallet can be placed by a fork lift truck at the input side.

- a) Pallet loading device in front of the lifting table. Loading from the left side (see sketch).
- b) see a), but with loading from the right side.
- c) Pallet loading device in cross direction:
  - A) loading station with wheeled conveyor lane.
  - B) lifting table with wheeled conveyor lane.
  - C) disposal station for empty pallet.
  - D) tray lifting station (see Ma).

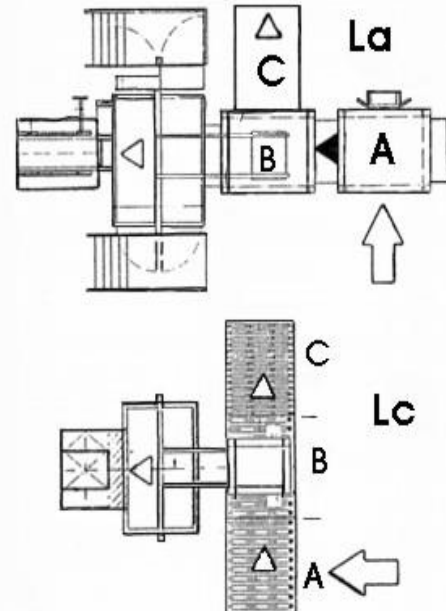

**M) Tray input**

For feeding trays into the SHA 81 the following devices are available:

- Ma) **lifting table**  
 Trays on a pallet will be lifted onto loading height (standard 1.100 mm).
- Mb) **Lift station\***  
 (max. 4 trays/min, without reversing device). Trays will be lifted one by one to loading height (standard 1.100 mm).

\*Advantage: - Trays on a pallet can be placed directly into the lift station of the SHA 81 by means of a fork lift.

More trays can be supplied for the SHA 81, as they can be placed directly on the floor (not on a lifting table).



**N) Polyvalence - Carton trays in both  
half and full EURO size**

- a) In this version the adjustability ranges from full down to half EURO size.  
Flap folding always on the side with 800 mm.  
Carton cut has to be modified accordingly.

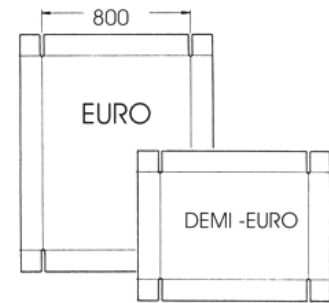

**O) Control of the machine**

For the SHA 81 standard version “central application” or “integrated application with a pneumatic tray stop” the following computer aided controls are available:

- 1) SIEMENS Simatic S 7-300 (standard)

Position of switch cabinet:

- a) The control is supposed to be in a switch cabinet close to the machine SHA.  
 b) Air conditioning is required (at temperature above 45°C in switch cabinet).  
 c) The control has to be in a control room and thus has to be delivered on a mounting frame.

The distance between machine and control room is \_\_\_\_\_ meters.

**P) Electric and pneumatic requirements**

- a) Standard: 415 Volt, 50 Hertz (cycles), with neutral.  
 b) We require \_\_\_\_\_ Volt, \_\_\_\_\_ Hertz, \_\_\_\_\_ neutral.  
 c) We confirm 4 – 6 bars air pressure is available.

**Q) Colour of the machine**

- a) Standard: grey, RAL 9006.  
 b) Moving parts (forming table, etc.) orange colour, RAL 2008.  
 c) Requested colour of the machine: \_\_\_\_\_ RAL \_\_\_\_\_

- I hereby agree that my personal data are stored.  
To delete your data, please contact us under info@mezger.eu

Please return the completed questionnaire to:

**MEZGER Heftsysteme GmbH**

Postfach (P.O.B.) 55 11 70  
D-90218 Nürnberg  
F.R. of Germany

Mail: info@mezger.eu  
Tel.: +49 (0)911 98494 0  
Fax: 0049 911 98494-30

Thank you for your efforts

Your MEZGER team

Copyright<sup>®</sup> by MEZGER Heftsysteme GmbH, Nuremberg, Germany